

## USAGE FOR CESSPIT EMTIERS, FOR CLEANING COMBINATION MACHINES

### GENERAL DEFINITIONS



- 27485 lb-ft vertical Split Shaft PTO is designed for Heavy Duty trucks with 3 stages.
- The gearbox can be installed as horizontal if needed.
- It can provide 100% of input speed.
- Control system can be pneumatic or mechanic.
- PTO shaft can be at differential side or cabin side.
- Second PTO output is an option.
- In case of double PTO output is requested, PTO outputs can be shifted independently.
- PTO outputs can be design with all ISO standard flanges as well as suitable housing for any kind of hydraulic pump.
- Cooling system can be mount on the gearbox.
- Engage/Disengage Sensor can be installed to observe, if PTO is engaged or not.
- RPM Counter is an option.

## USAGE FOR CESSPIT EMTIERS, FOR CLEANING COMBINATION MACHINES

### PTO OUTPUT DEFINITIONS

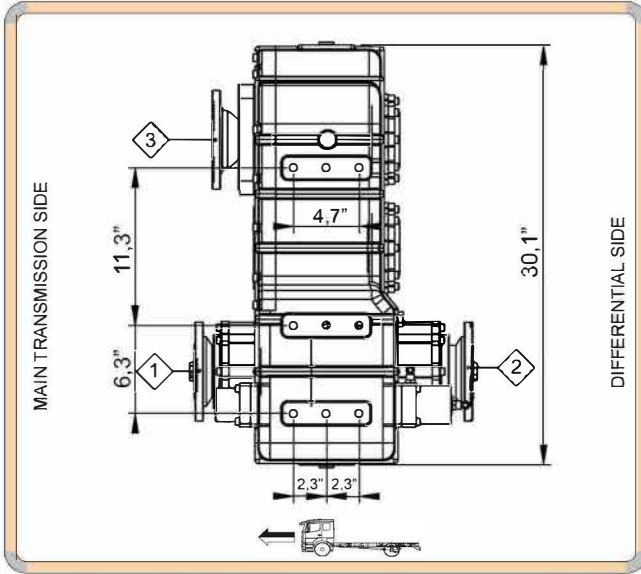
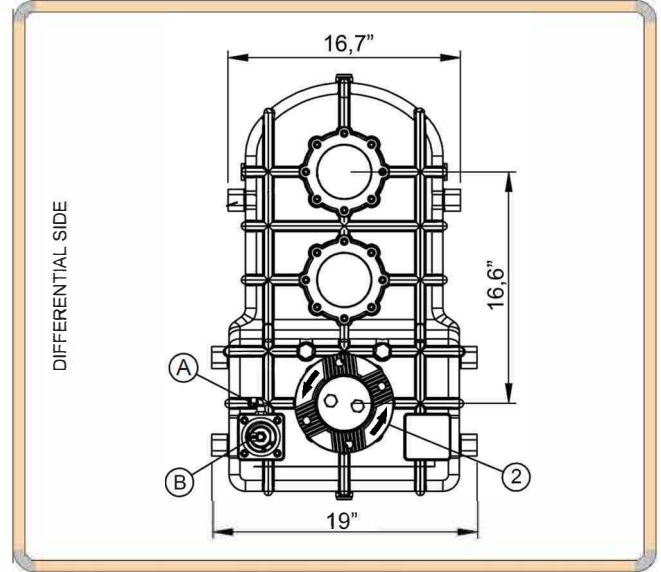
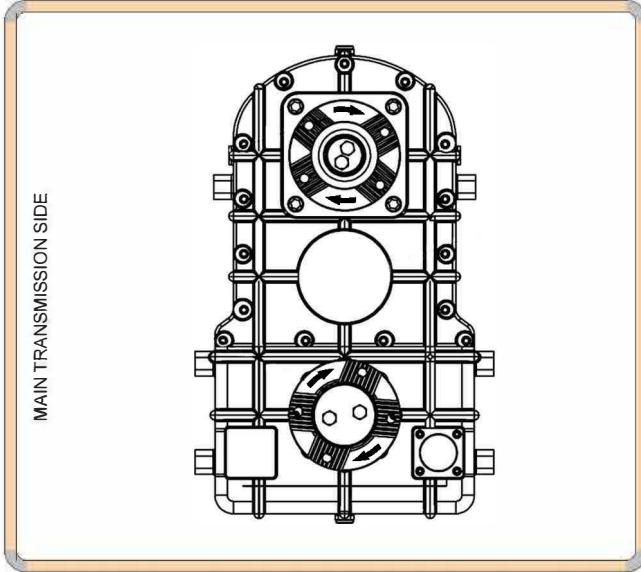

(1)	Input Side
(2)	Output Side
(3)	PTO Output
(A)	Air Inlet (Engage)
(B)	Air Inlet (Disengage)

- Kozmaksan has all rights to change information in this catalogue without announcing it. This document is representing general information. It is not a contract.
- All information belongs to only PTO/Split Shaft. Do not use PTO/Split Shaft, if it is not suitable for your engine and main transmission.
- Pumps, shafts and other parts should not be longer or heavier than approved distance and weight by the manufacturer of main transmission and engine.

Please Contact with KOZMAKSAN, If You Have Any Question or Concern

Adress : 06370 TURKEY Phone: +903122673971

E-Mail : export@zmaksan.com.tr

Website: www.kozmaksan.net

## USAGE FOR CESSPIT EMTIERS, FOR CLEANING COMBINATION MACHINES

### TECHNICAL INFORMATION

TECHNICAL VALUES			
	MAX. VALUES	INTERNAL RATIO	MAX. RPM
① & ②	3800 kgm	1/1	-
③	350 kW	1/1.3 - 1/1.1	2500 rpm-3500 rpm

WEIGHT	250 kg
BODY MATERIAL	GH190
KIND OF OIL QUANTITY	80W90 15 lt

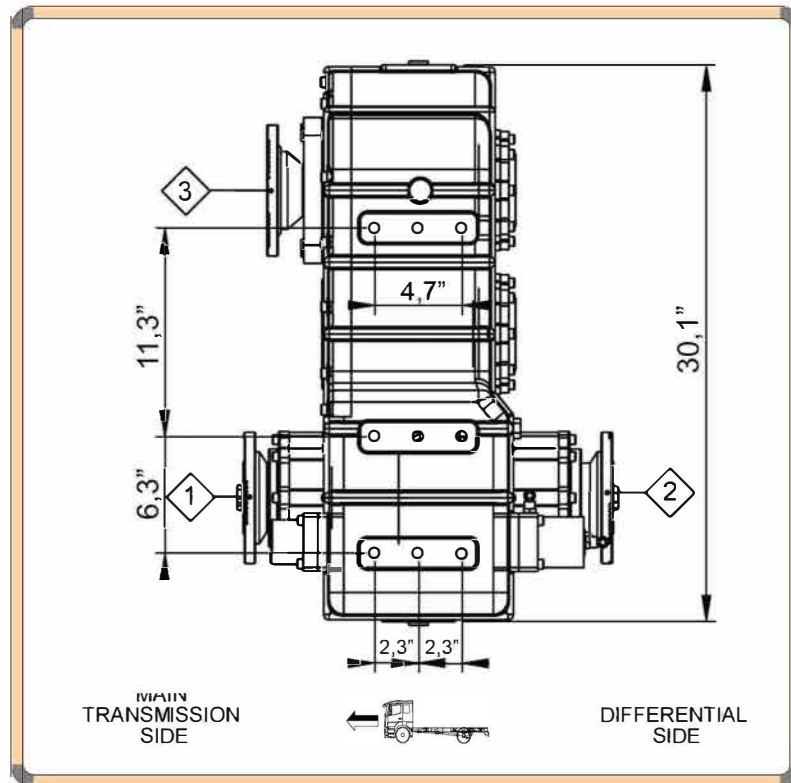

- Kozmaksan has all rights to change information in this catalogue without announcing it. This document is representing general information. It is not a contract.
- All information belongs to only PTO/Split Shaft. Do not use PTO/Split Shaft, if it is not suitable for your engine and main transmission.
- Pumps, shafts and other parts should not be longer or heavier than approved distance and weight by the manufacturer of main transmission and engine.

Please Contact with KOZMAKSAN, If You Have Any Question or Concern

Adress : 06370 TURKEY Phone: +903122673971

E-Mail : [export@zmaksan.com.tr](mailto:export@zmaksan.com.tr)

Website: [www.kozmaksan.net](http://www.kozmaksan.net)